

BAYLAN

WATER METERS

KK-12

Single jet Dry type Water Meter



GENERAL

- MID Certificated
- Single jet design assures very high sensitivity even at low flows
- Pulse output and AMR reading features are optional
- Plastic upper body with high resistance to pressure and impacts
- 359° rotating dial
- Vacuum mechanism
- Electrostatic painted body made of corrosion resistant brass
- Protection against external magnetic fields
- Suitable for potable water
- Available for optical reading
- 3 years of warranty • Almost no maintenance
- Suitable for cold water up to 50°C
- Service and spare parts available for 10 years
- IP68 Protected
- Environmental Classes

Climatic : -10°C/+55°C | Mechanic: M1/O | Elektromagnetic: E2

- $Q_2 \leq Q \leq Q_4$ Maximum Permissible Error

Class 2 Water Meters; $\% \pm 2$ (Water Temp. $\leq 30^\circ\text{C}$), $\% \pm 3$ (Water Temp. $> 30^\circ\text{C}$)

Class 1 Water Meters; $\% \pm 1$ (Water Temp. $\leq 30^\circ\text{C}$), $\% \pm 2$ (Water Temp. $> 30^\circ\text{C}$)

- $Q_1 \leq Q < Q_2$ Maximum Permissible Error

Class 2 Water Meters; $\% \pm 5$ | Class 1 Water Meters; $\% \pm 3$

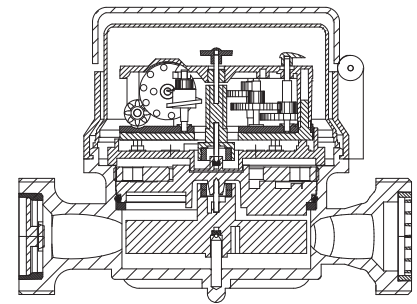

PERFORMANCE DATA

Overload Flowrate	Q4	m ³ /h	3,125	
Permanent Flowrate	Q3	m ³ /h	2,5	
Transitional Flowrate	Q2	m ³ /h	0,020	0,050
Minimum Flowrate	Q1	m ³ /h	0,0125	0,03125
Q3/Q1 (MI-001 OIML R49)	-		≤ 200	≤ 80
Mounting on the network	-		H	V
Maximum Registration Capacity	m ³	9999 / 99999 / 99999,99 / 99999,999		
Initial Flow	Qi	l/h	5	
Maximum Working Pressure	bar	16		
Maximum Working Temperature	°C	50		
Pressure Loss Class	bar	0,63		
Smallest Reading Resolution	m ³ /h	0,00005		
Class	-	Class 1/Class 2		
Quantity per package	-	10		
Package dimensions	cm	21x43x17		

PRESSURE LOSS CURVE

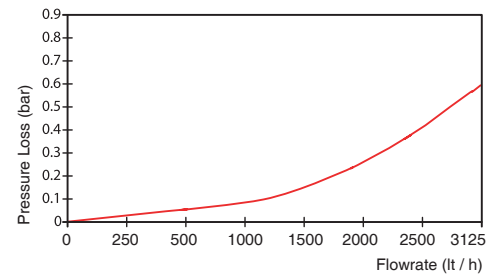

PERFORMANCE CURVE

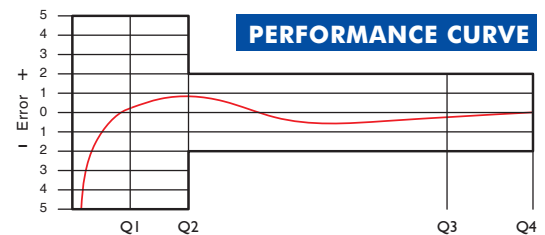

DIMENSIONS

Nominal diameter	DN	15	20	mm
Connecting diameter	D	G 3/4	G 1	B
Total overall meter height	H	84,7	84,7	mm
Axis height	h	17	17	mm
Length	L	110/115	110/115	mm
Width	B	74,5	74,5	mm
Length with connections	LB	190/195	190/195	mm
Unit weight		0,53	0,54	kg
Package Weight (without connections)		5,86	5,90	kg
Package Weight (with connections)		7,46	7,80	kg

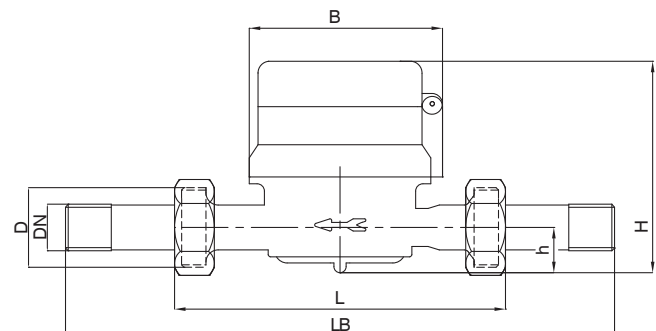

"Due to continuous development of our products, we reserve the right to modify our product design or construction without prior notice."