

BAYLAN

WATER METERS

Agricultural Irrigation Elastomer Seat Gate Valve



GENERAL

- Low pressure loss
- Suitability for drinking water
- Painting with interior/exterior thermoplastic powder paint
- High corrosion and UV resistance
- Body GGG-40 (Ductile iron)
- Does not disrupt the flow profile
- High security
- Superior quality production
- 100% sealing
- Easy opening/closing even under pressure with low torque value
- Fasteners and internal parts are made of stainless material
- Works without breaking down for years
- Service and spare parts available for 10 years

It is used in front of water pipelines feeding agricultural irrigation hydrants.

Elastomer Seat Gate Valves are valves used as network shut-off valves and relief valves. Although there is no slide slot in the body, they provide full sealing thanks to their completely EPDM rubber covered slides. It prevents water waste and energy consumption.

DIMENSIONS & WEIGHTS

TYPE	SIZE DIA DN	LB LENGTH	H HEIGHT	B WIDTH	h AXIS HEIGHT	CONNECTION BOLT (PCS-DIA)	OUTPUT CONNECTION BOLT	WEIGHT (kg)
Gate Valve	100	192	373	220	103	16 - M16	4-M16	

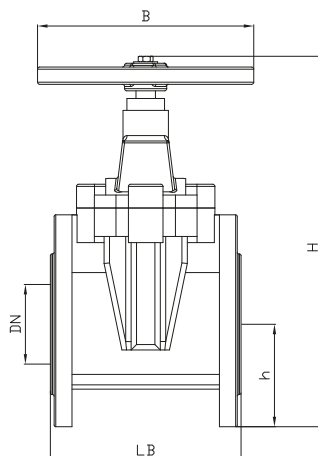

"Due to continuous development of our products, we reserve the right to modify our product design or construction without prior notice."