

# BAYLAN

## WATER METERS

### Monoblock Agricultural Irrigation Hydrant with Valve



#### GENERAL

- Remote valve opening and closing (Optional)
- Flow limitation (Optional)
- Pressure regulation (Optional)
- Illuminated Graphic Display LCD (Optional)
- Low pressure loss
- Painting with interior/exterior thermoplastic powder paint
- High corrosion and UV resistance
- WRAS approved coating
- Safe against freezing
- Body GGG-40 (Ductile iron)
- Fasteners and internal parts are made of stainless material
- Long-lasting lithium battery
- Internal components suited to come into contact with drinking water
- Works without breaking down for years
- Service and spare parts available for 10 years

Agricultural water intake valves can be connected to irrigation networks remotely when it's necessary. It is used to transmit the necessary water to agricultural lands by controlling it. That water intake valves placed at water outlet points, apart from field conditions, it ensures that all users use water under equal conditions at the desired pressure and flow rate in the water intake valves.

It will decrease water loss and energy loss. If you are planning to take maximum efficient from water intake valve, you should assemble your water intake valve and water meter without any mistake.

#### DIMENSIONS & WEIGHTS

TYPE	INPUT DIA D	OUTPUT DIA DN	LB LENGTH	H HEIGHT	B WIDTH	h AXIS HEIGHT	CONNECTION BOLT (PCS-DIA)	OUTPUT CONNECTION BOLT	WEIGHT (kg)
Dual Output	100	80	600	403	220	180	16 - M16	4-M16	35/37

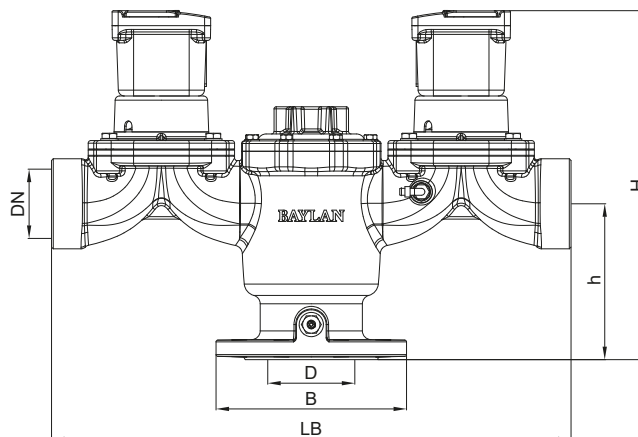

"Due to continuous development of our products, we reserve the right to modify our product design or construction without prior notice."