

# BAYLAN

## WATER METERS



### BSH-4

## Water Meters Intake Valve Single Output

#### GENERAL

Type 4 Irrigation Hydrant

- With RF-LoRa® -Smart Card
- Opening and closing
- Flow measurement
- Flow limitation (Optional max. 10-12 l/s)
- Pressure regulation (Optional 3-3.8 Bar)
- Rated Pressure PN10/ PN16
- Ductile Iron EN GJS400-15
- Suitable for irrigation water purposes
- MID Certified
- Reverse flow detection
- Integrated LoRa® module-chipset allows both LoRa® and FSK modulation
- Supports LoRaWAN® - Class A / Class B Protocol
- IP 68 protection class • Supports Wireless MBUS Protocol
- Thermoplastic coating suitable for drinking water
- Can be mounted all positions desired
- Lithium battery, 10 years lifetime • No measurement of air
- Due to the lack of moving parts, high measurement accuracy parameters, which is not possible to modify externally
- Via the LCD display providing access to meter data for Billing and check out

Turning on and off Valve ( It will take 30-45 seconds from open position to completely close position)	Nominal diameter of the flow limiter is 80mm. Maximum admissible pressure of flow limiter is PN16.
While water intake valve operating at effective flow, The pressure loss is 0,8 Bar.	Pressure loss for debi limiter is 0.8 bar. Pressure regulator can connect with screws.
Water intake valve is entegrated with UC-80 water meter.	Maximum admissible pressure of pressure regulator is PN16.
Nominal diameter of the water meter is 80mm.	Maximum admissible air pressure of pressure regulator is 17,6 Bar.
Maximum admissible pressure of water meter is PN16.	
Metrological class of water meter is Class B.	Nominal flow for pressure regulator is 36 m3/h
Nominal Flow is 63 m3/h	Nominal pressure is PN10/PN16
Flow limiter can connect with screws. (Optional: max 10-12 l/s)	

#### USAGE METHODS

- 1) Storage: After they passed all production tests , Water intake valves and UC-80 water meters will be packaged with protective foams.
- 2) Assignment and Operational tryings: Agricultural water intake valves can be connected to irrigation networks remotely when it's necessary. It is used to transmit and measure the necessary water to agricultural lands by controlling it. That water intake valves placed at water outlet points, apart from field conditions, it ensures that all users use water under equal conditions at the desired pressure and flow rate in the water intake valves. It will dissincrease water loss and energy loss. If you are planning to take maximum efficient from water intake valve, you should assemble your water intake valve and water meter without any mistake.
- 3) Maintenance and Repairing: a) It works for years without any problem and maintains the accuracy and precision as like first day. b) Years of spare parts and service support.

#### DIMENSIONS & WEIGHTS

TYPE	INPUT DIA DNB	OUTPUT DIA DNP	L3 LENGTH	H CENTER OUTPUT LENGTH	B WIDTH	L2 HEIGHT	L1 AXIS HEIGHT	CONNECTION BOLT (PCS-DIA)	OUTPUT CONNECTION BOLT (PCS-DIA)	WEIGHT (kg)
Single Output	100	80	689	548	220	405	180	16 - M16	4-M16	42

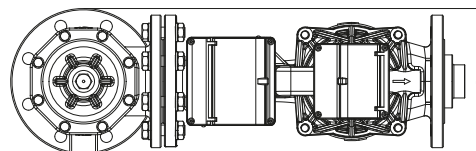
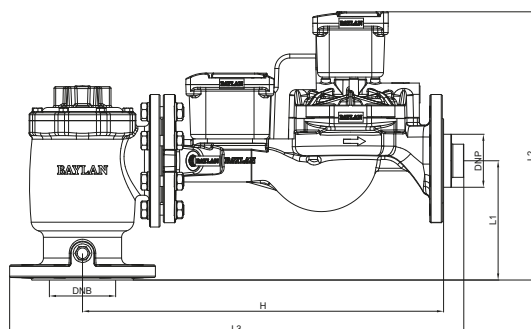

"Due to continuous development of our products, we reserve the right to modify our product design or construction without prior notice."